



soil moisture
cci

Input/Output Data Definition Document (IODD v2)

Version 2.0
19 December 2013

Prepared by

TU Wien, VUA, GeoVille, ETH Zürich, AWST, FMI, UCC and NILU



FMI



This document forms deliverable D3.8 and was compiled for the ESA Climate Change Initiative Phase 1 Soil Moisture Project (ESRIN Contract No: 4000106302 (4000104814/11/I-NB)). For more information on the CCI programme of the European Space Agency (ESA) see <http://www.esa-cci.org/>.

Number of pages: 22

Authors:	R. Kidd, D. Chung, W. Dorigo, R. De Jeu		
Circulation (internal):	Project consortium and science partners		
External:	ESA		
Issue	Date	Details	Editor
0.1	10-10-12	Document created	R. Kidd
0.2	29-11-12	Structure Revision, and delivered as Draft to ESA for review	R. Kidd
0.3	12-12-12	Inclusion of overview diagram and revision of structure	R.Kidd, D. Chung
0.4	12-12-12	For input of data structure tables and figures	D. Chung
1.0	21-12-12	Integration and revision for delivery	R. Kidd
2.0	18-12-13	Revision of temporal resampling and review and edit of document for delivery	R. Kidd

For any clarifications please contact Richard Kidd (rk@ipf.tuwien.ac.at).



Table of Content

LIST OF FIGURES.....	IV
LIST OF TABLES	IV
DEFINITIONS, ACRONYMS AND ABBREVIATIONS	V
PROCESSING LEVELS.....	VI
1 EXECUTIVE SUMMARY	1
2 INTRODUCTION.....	1
2.1 PURPOSE OF THE DOCUMENT	1
2.2 TARGETED AUDIENCE.....	2
3 DOCUMENTS.....	2
3.1 APPLICABLE DOCUMENTS	2
3.2 REFERENCE DOCUMENTS	2
3.3 BIBLIOGRAPHY	3
4 OVERVIEW OF THE ECV PRODUCTION SYSTEM	4
5 I/O FOR MERGING ALGORITHM	5
5.1 INPUT DATA	6
5.1.1 AMI-WS	7
5.1.2 ASCAT	7
5.1.3 SMMR	7
5.1.4 SSM/I.....	8
5.1.5 TMI.....	8
5.1.6 AMSR-E.....	8
5.1.7 GLDAS NOAH Average Layer 1 (0 – 10cm) Soil Moisture	9
5.1.8 GLDAS Soil Porosity.....	9
5.1.9 Correlation Coefficient	9
5.1.10 Vegetation Optical Depth.....	9
5.2 RESAMPLING.....	10
5.2.1 Temporal Resampling.....	10
5.2.2 Spatial Resampling.....	10
5.2.3 Data structure after resampling.....	11
5.3 RESCALING	11
5.4 ACTIVE MERGING AND PASSIVE MERGING.....	12
5.5 RESCALING TO GLDAS CLIMATOLOGY.....	13
5.6 COMBINING ACTIVE AND PASSIVE MERGED DATA.....	14



6	VALIDATION DATASETS	ERROR! BOOKMARK NOT DEFINED.
6.1	ISMN	ERROR! BOOKMARK NOT DEFINED.
6.2	GLDAS	ERROR! BOOKMARK NOT DEFINED.
7	CONCLUDING COMMENTS	ERROR! BOOKMARK NOT DEFINED.
8	BIBLIOGRAPHY	15



List of Figures

Figure 5-1. An overview of processes in the ECV SSM product generation 6

Figure 5-3: Processing step 1: Resampling of the input data sets 10

Figure 5-4: Processing step 2: Rescaling 11

Figure 5-5 Processing step 3: Active Merging and Passive Merging..... 12

Figure 5-6: Processing step 4: Rescaling to GLDAS climatology..... 13

Figure 5-7 Processing step 5: Combining Active and Passive Merged data..... 14

Figure 5-8 Spatial and temporal coverage of soil moisture products from different sensors in the final product..... 15

List of Tables

Table 8-1 Processing Level Codes for Remotely Sensed Data Sets..... vi

Table 5-1: Level 2 Active AMI WS data 7

Table 5-2: Level 2 Active ASCAT data 7

Table 5-3 Level 2 Passive SSMR data..... 7

Table 5-4 Level 2 Passive SSM/I data 8

Table 5-5 Level 2 Passive TMI data 8

Table 5-6 Level 2 Passive AMSR-E data 8

Table 5-7 Ancillary Data GLDAS NOAH Average Layer Soil Moisture 9

Table 5-8 Ancillary Data GLDAS Soil Porosity..... 9

Table 5-9 Ancillary Data Correlation Coefficient..... 9

Table 5-10 Ancillary Data Vegetation Optical Depth (VOD)..... 9

Table 5-11 Data Structure after resampling..... 11

Table 5-12 Data Structure provided to the final product 15



Definitions, acronyms and abbreviations

AMI-WS	Active Microwave Instrument - Windscat (ERS-1 & 2)
AMSR-E	Advanced Microwave Scanning Radiometer-Earth Observing System
ANO	Anomaly
AQUA	NASA Earth Science satellite mission (formerly EOS-PM)
ASCAT	Advanced Scatterometer (Metop)
ATBD	Algorithm Theoretical Basis Document
CDF	Cumulative Distribution Function
DARD	Data Access and Retrieval Document
DGG	Discrete Global Grid
DPM	Detailed Processing Model
ECV	Essential Climate Variable
ERS	European Remote Sensing Satellite (ESA)
ERS	European Remote Sensing Satellite (ESA)
ESA	European Space Agency
ESD	Estimated Standard Deviation
GLDAS-Noah	Global Land Data Assimilation System- Noah model
IODD	Input Output Data Definition Document
LPRM	Land Parameter Retrieval Model
LUT	Look Up Table
METOP	Meteorological Operational Satellite (EUMETSAT)
NASA	National Aeronautics and Space Administration
ORI	Original (Time Series)
PSD	Product Specification Document
SM	Soil Moisture
SMMR	Scanning Multichannel Microwave Radiometer
TMI	TRMM Microwave Imager
TRMM	Tropical Rainfall Measuring Mission
UTC	Coordinated Universal Time
VOD	Vegetation Optical Depth
WARP	soil Water Retrieval Package



Processing Levels¹

Level	<ProcessingLevel> Code	Description	Based on Source
Level 0	L0	Unprocessed instrument and payload data at full resolution. GHRSSST	
Level 1A	L1A	Reconstructed unprocessed instrument data at full resolution, time referenced, and annotated with ancillary information, including radiometric and geometric calibration coefficients and georeferencing parameters, computed and appended, but not applied, to L0 data.	GHRSSST
Level 1B	L1B	Level 1A data that have been processed to sensor units.	GHRSSST
Level 1C	L1C	Level 1B data that have been further processed, eg by correcting radiances or by mapping onto A spatial grid, prior to deriving geophysical variables from the data.	SMOS data products definition
Level 2	L2	Retrieved environmental variables at the same resolution and location as the level 1 source.	CEOS handbook ²
Level 2Pre-processed	L2P	Geophysical variables derived from Level 1 source data at the same resolution and location as the level 1 data, typically in a satellite projection with geographic information. These data form the fundamental basis for higher-level CCI products.	GHRSSST
Level 3	L3	Level 2 variables mapped on a defined grid with reduced requirements for ancillary data. Three types of L3 products are defined:	GHRSSST
	L3U	Uncollated (L3U): L2 data granules remapped to a space grid without combining any observations from overlapping orbits.	
	L3C	Collated (L3C): Observations combined from a single instrument into a space-time grid.	
	L3S	Super-collated (L3S): observations combined from multiple instruments into a space-time grid.	
Level 4	L4	Data sets created from the analysis of lower level data that result in gridded, gap-free products.	GHRSSST

Table 8-1 Processing Level Codes for Remotely Sensed Data Sets

¹ Extracted from [RD-4]

² http://wiki.ieee-earth.org/@api/deki/files/7/=Handbook_0802.pdf



1 Executive Summary

This document provides a complete list, and technical description, of the data products used and generated by the Soil Moisture prototype ECV production system (PECVPS). It provides an overview of the data structures, formats, and data flows within the PECVPS to enable system engineers to better understand and implement the PECVPS, and finally provides the technical description of the content of the final ECV SM product.

2 Introduction

The Input/Output Data Definition Document (IODD) aims to provide a complete list and a detailed technical description of all data products used for and generated by the prototype processing system.

It describes the format, structure and data ranges of all

- required satellite input data,
- auxiliary files
- generated output products

The IODD focuses on the data flows from the ingestion of level 2 active and passive data into the ECV processing system to the generation of the level 3 ECV soil moisture product. An overview of the data flows that are covered is provided in Figure 5-2, and can be seen comprise of data flows between the following processes; resampling, rescaling, active merging and passive merging, rescaling to GLDAS climatology, and combing active and passive merged data. The IODD covers both the data flowing into and out from the processes.

2.1 Purpose of the document

The purpose of this Input/Output Data Definition Document is to provide an overview of the data structures and formats of the data flows within the ECV prototype production system. The document is provided to enable system engineers to understand and implement the production system as outlined in the Detailed Processing Model (DPM), as provided [RD-4].

The document does not duplicate information already provided in the Data Access Requirement Document (DARD) deliverable (D1.3) or in the product specification documents (PSD) deliverable D1.2, which provides the complete specification of the ECV SM output product.



2.2 Targeted audience

This document targets mainly

- IT experts and system design engineers working within the CCI SM project
- IT experts and system design engineers working to install ECV production system

3 Documents

3.1 Applicable documents

The documents outlined here detail the scope and focus for the work that is reported in this document.

[AD-1] Phase 1 of the ESA Climate Change Initiative Soil- Moisture- cci. ESRIN Contract No: 4000104814/11/I-NB

[AD-2] ESA Climate Change Initiative Phase 1, Statement of Work for Soil Moisture and Ice Sheets, European Space Agency, EOEP-STRI-EOPS-SW-11-0001.

[AD-3] Technical Proposal (Part 3) in response to ESA Climate Change Initiative Phase 1 ESRIN/AO/1-6782/11/I-NB, Vienna University of Technology.

3.2 Reference documents

The section provides a list of references documents upon which this document is either based, or is required to be referenced by the reader in order to obtain the full information intended by the authors.

[RD-1] Algorithm Theoretical Baseline Document (ATDB) Version 0, Climate Change Initiative Phase 1 Soil Moisture Project, 30th April 2012, <http://www.esa-soilmoisture-cci.org/node/119>

[RD-2] Data Access Requirements Document (DARD), Version 1.2, Climate Change Initiative Phase 1 Soil Moisture Project, 13th April 2012, <http://www.esa-soilmoisture-cci.org/node/119>

[RD-3] Product Specification Document (PSD), version, 0.3, Climate Change Initiative Phase 1 Soil Moisture Project, 18th June 2012, <http://www.esa-soilmoisture-cci.org/node/119>

[RD-4] Detailed Processing Model (DPM), Version 1.0, Climate Change Initiative Phase 1 Soil Moisture Project, 28th September 2012, <http://www.esa-soilmoisture-cci.org/node/119>



3.3 Bibliography

A complete bibliographic list, detailing scientific text or publications that support arguments or statements made within the current document is provided in section 8.



4 Overview of the ECV production system³

The Soil Moisture ECV production system starts from level 1 calibrated backscatter values and level 1 calibrated brightness temperatures for scatterometers and radiometers, respectively. The ECV production system requires a modular system design where new or updated level 2 datasets can be easily ingested, quality controlled, and assimilated in the ECV production. In Phase I of the project, only input level 2 products based on the TU Wien method (for scatterometers) and the VUA-NASA LPRM algorithm (for radiometers) are considered. This results in the following structure of the ECV production system:

- A. Level 2 soil moisture retrieval for individual scatterometer data sets using the TU Wien method as first (Wagner et al., 1999).
- B. Level 2 soil moisture retrieval for single radiometer data sets using the VUA-NASA method (Owe et al., 2008).
- C. Fusion of the active Level 2 data sets into a homogenized active surface soil moisture ECV.
- D. Fusion of the passive Level 2 data into a homogenized passive surface soil moisture ECV.
- E. Fusion of the merged active and passive data sets from steps 2 and 3 into homogenized active+passive surface soil moisture ECV.

This IODD document provides a description of the data flows between the processes involved in the production system from the level 2 data input data to the generation of the level 3 ECV product and therefore only addresses points C,D and E. An overview of the processes included in this document is provided in Figure 5-2.

³ Adapted from [RD-4]



5 I/O for merging algorithm

Level 2 derived soil moisture products from active and passive space borne systems form the main inputs to the merging algorithm of the ECV prototype production system and are supported by a limited set of ancillary data as shown in Figure 5-2.

A detailed view of the data flows within the 5 main processing steps in the merging process, namely resampling, rescaling, active merging and passive merging, rescaling to GLDAS climatology, and combining active and passive merged data are provided in the following subsections. In the following document the pre-processing steps concerning a “re-shuffling” of the input data are not considered, but the process is included in Figure 5-1 to provide a complete overview of the PECVPS.

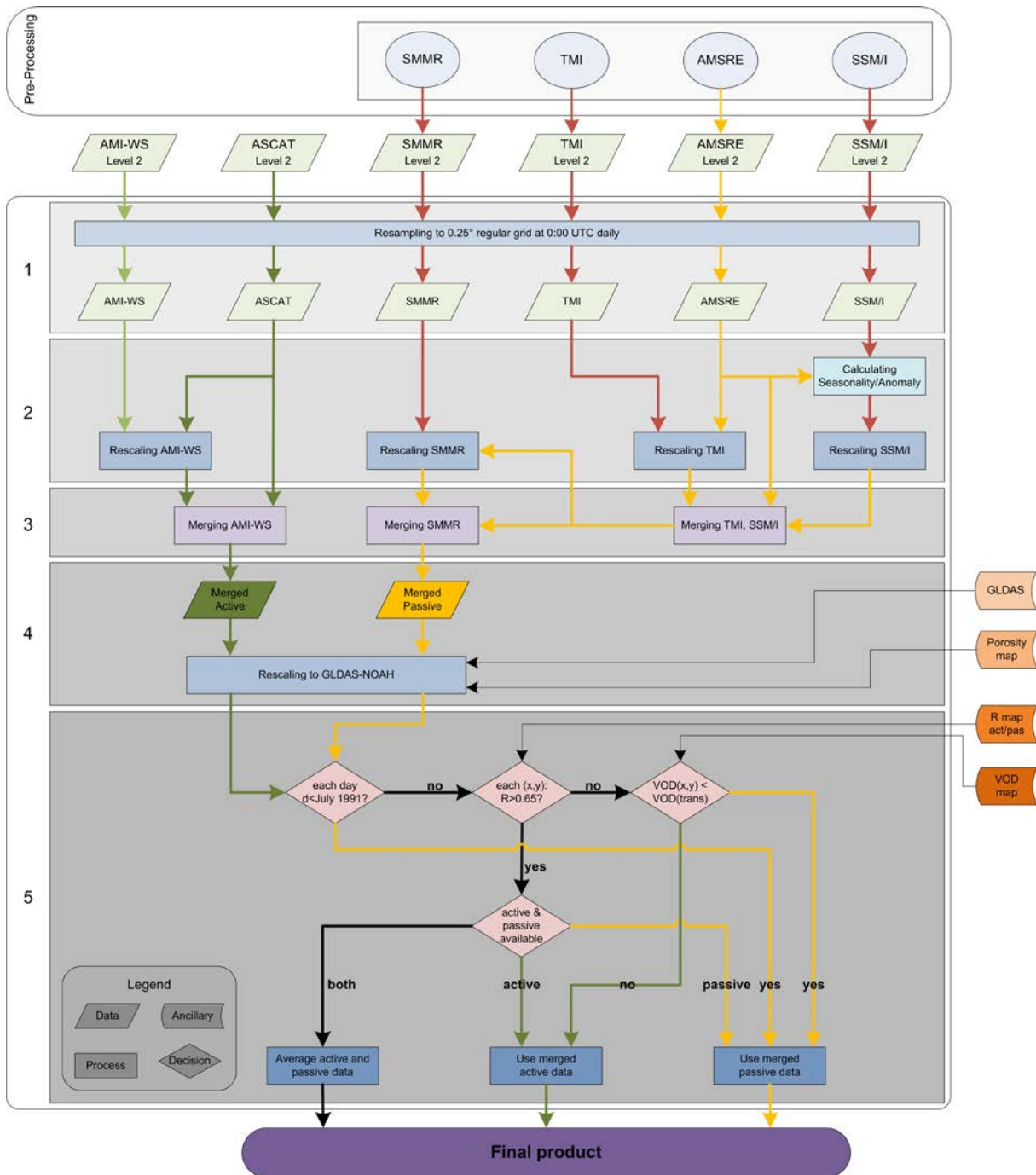

Figure 5-1. An overview of processes in the ECV SSM product generation

5.1 Input data

The following tables show all required level 2 soil moisture input data including four ancillary data sets.



5.1.1 AMI-WS

Variable	Type	Offset	Scale	Min physical value	Max physical value	Unit	Missing Value
JD	double precision float	0	1	2448473.5 05-AUG-1991	2454252.499 31-MAY-2007	day	-999999.
SM	float	0	1	0	100	%	-999999.
SM_NOISE	float	0	1	0	100	%	-999999.
FLAG	byte	0	1	0	255	–	255

Table 5-1: Level 2 Active AMI WS data

5.1.2 ASCAT

Variable	Type	Offset	Scale	Min physical value	Max physical value	Unit	Missing Value
JD	double precision float	0	1	2448473.5 05-AUG-1991	2454252.499 31-MAY-2007	day	-999999.
SM	float	0	1	0	100	%	-999999.
SM_NOISE	float	0	1	0	100	%	-999999.
FLAG	byte	0	1	0	255	–	255
DIR	String	0	–	'A'	'D'	–	255
PDB	byte	0	1	0	255	–	255
SSF	byte	0	1	0	255	–	255

Table 5-2: Level 2 Active ASCAT data

5.1.3 SMMR

Variable	Type	Offset	Scale	Min physical value	Max physical value	Unit	Missing Value
JD	Double precision Float	0	1	2443810.193 28-OCT-1978	2447022.193 14-AUG-1987	day	-1
SMC	Byte	0	1	0	100	%	255.
OPTC	Byte	0	1	0	100	%	255
FLAG	Byte	0	1	0	255	–	255
MODE	Byte	0	1	65 ('A')	68 ('D')	–	255
RFI	Byte	0	1	0	255	–	255
LST	Integer	0	1	0	255	–	-9999

Table 5-3 Level 2 Passive SSMR data



5.1.4 SSM/I

Variable	Type	Offset	Scale	Min physical value	Max physical value	Unit	Missing Value
DT	Double precision Float	0	1	2446984.5 08-JUL-1987	2454647.5 30-JUN-2008	day	-1
VALUE	Byte	0	1	0	100	%	255.

Table 5-4 Level 2 Passive SSM/I data

5.1.5 TMI

Variable	Type	Offset	Scale	Min physical value	Max physical value	Unit	Missing Value
DT	Double precision Float	0	1	2446984.5 08-JUL-1987	2454647.5 30-JUN-2008	day	-1
VALUE	Byte	0	1	0	100	%	255.

Table 5-5 Level 2 Passive TMI data

5.1.6 AMSR-E

Variable	Type	Offset	Scale	Min physical value	Max physical value	Unit	Missing Value
JD	double precision float	0	1	2452444.5 19-JUN-2002	2455838.499 03-OCT-2011	day	-1
SMC	Integer	0	1.0	0	100	%	-32678
SMX	Integer	0	1.0	0	100	%	-32678
SMC_ERROR	Integer	0	0.01	0	100	%	-32678
SMX_ERROR	Integer	0	0.01	0	100	%	-32678
OPTC	Integer	0	0.01	0	-	-	-32678
OPTX	Integer	0	0.01	0	-	-	-32678
MASK	Integer	0	1	0	-	-	-32678
RFI	Integer	0	1	-	-	-	-32678
MODE	Byte	0	1	65 ('A')	68 ('D')	-	255
RES_C	Integer	0	0.1	0	-	Kelvin	-32678
RES_X	Integer	0	0.1	0	-	Kelvin	-32678
TS	Integer	0	0.1	0	-	Kelvin	-32678

Table 5-6 Level 2 Passive AMSR-E data

**5.1.7 GLDAS NOAH Average Layer 1 (0 – 10cm) Soil Moisture**

Variable	Type	Offset	Scale	Min physical value	Max physical value	Unit	Missing Value
DT	Double precision Float	0	1	2451544.5 01-JAN-2000	2456200.5 30-SEP-2012	day	-1
VALUE	Byte	0	1	0	100	kgm ⁻³	255.

Table 5-7 Ancillary Data GLDAS NOAH Average Layer Soil Moisture

5.1.8 GLDAS Soil Porosity

Variable	Type	Offset	Scale	Min physical value	Max physical value	Unit	Missing Value
VALUE	Float	0	1	0	100	%	-99999.

Table 5-8 Ancillary Data GLDAS Soil Porosity

5.1.9 Correlation Coefficient

Variable	Type	Offset	Scale	Min physical value	Max physical value	Unit	Missing Value
R	Float	0	1	0	1	–	-99999.

Table 5-9 Ancillary Data Correlation Coefficient

5.1.10 Vegetation Optical Depth

Variable	Type	Offset	Scale	Min physical value	Max physical value	Unit	Missing Value
JD	Double precision float	0	1	2447161.5 01-JAN-1988	2455838.5 03-OCT-2011	day	-99999.
VOD	Float	0	1	0	1	–	NaN
SENSOR	Byte	0	1	1	10		255

Table 5-10 Ancillary Data Vegetation Optical Depth (VOD)



5.2 Resampling

The input data sets AMI-WS, ASCAT, SMMR, AMSR-E, TMI, and SSM/I are fed in to the resampling process to transform them into a harmonized data format

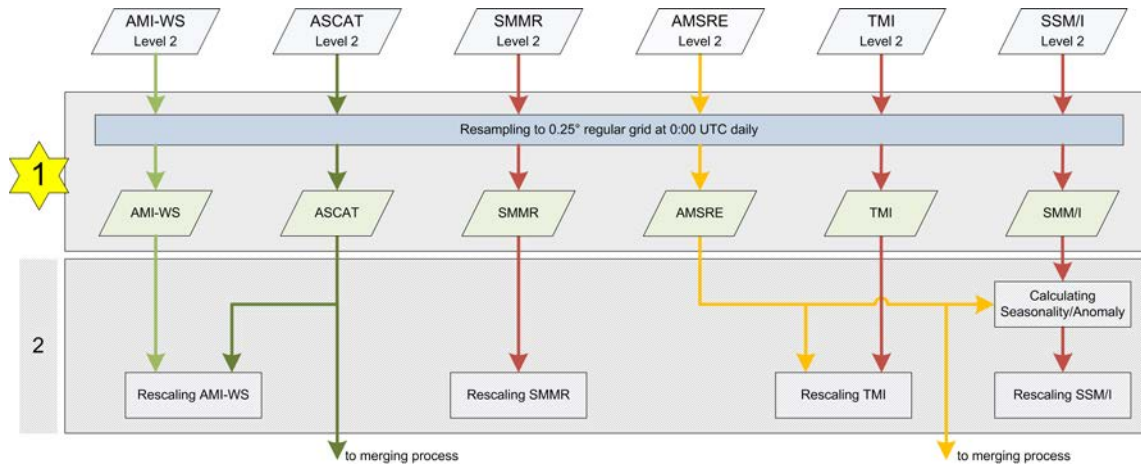

Figure 5-2: Processing step 1: Resampling of the input data sets

5.2.1 Temporal Resampling

The temporal resolution of the merged product is 6 hours. The reference time for the merged dataset is set at 0:00, 06:00, 12:00, and 18:00 UTC. For each reference time step, the observations within ± 3 hours around the time step are considered. If more than one observation falls within the 6 hours time frame, the observation closest to the reference time is selected. This strategy results in data gaps when no observations within ± 3 hours from the reference time are available. For the modelled soil moisture datasets no resampling is required.

5.2.2 Spatial Resampling

Nearest neighbour resampling is performed to convert the various grid systems into the common 0.25 degree regular grid. For each grid point in the reference (regular grid) data set, this resampling technique receives the value of the closest grid point in the input dataset.



5.2.3 Data structure after resampling

Variable	Type	Offset	Scale	Min physical value	Max physical value	Unit	Missing Value
JD	Double precision float	0	1	2443813.5 01-NOV-1991	2455561.5 31-DEC-2010	day	-999999.
SM	Float	0	1	-	-	-	-999999.
SM_NOISE	Float	0	1	0	-	-	-999999.
FLAG	Byte	0	1	0	255	-	255
SENSOR	Byte	0	1	1	10'	-	255

Table 5-11 Data Structure after resampling

The values for julian date (JD) are set according to the resampling algorithm. Soil moisture and soil moisture noise values come untouched from its original data set. Flag values are not set in this processing step but in the merging step 3 and 5. Depending on the input data, the sensor variable will be assigned to values from 1 to 10, with respect to their input sensors SMMR (1), SSM/I (2), TMI (3), AMSR-E (4), AMI-WS (5), ASCAT (6). Values from 7 to 10 will be used for the merged data (see merging processing step 3 and 5).

As shown in Figure 5-3 ASCAT and AMR-E data are used as reference for the rescaling process of the AMI-WS, TMI, SSM/I, and SMMR. The latter is rescaled against the merged climatology of SSM/I and TMI with AMSR-E (after their rescaling, see overview Figure 5-2). As reference data sets and after rescaling, ASCAT and AMSR-E are directly fed into the merging process.

5.3 Rescaling

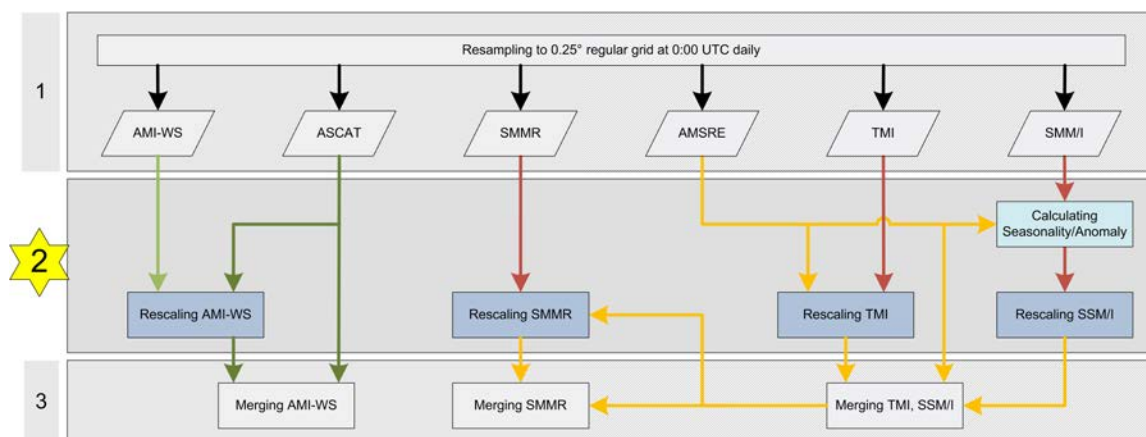

Figure 5-3: Processing step 2: Rescaling

Before merging can take place the data sets need to be rescaled by CDF matching into a common climatology. Figure 5-4 shows that ASCAT is used as reference (climatology) to



rescale the AMI-WS on the active microwave soil moisture data, whereas AMSR-E is the reference data set for all rescaling procedure on the passive data side. Due to atmospheric influences on SSM/I – this issue is described in the ATBD section 8.3.1.1.2 – its rescaling needs the calculation seasonality and anomaly of the AMSR-E and SSM/I. The rescaling of SMMR needs the merged TMI, SSM/I and ASMR-E, which is produced in processing 3, as input reference data.

The rescaled soil moisture and soil moisture noise data (see section 5.2.3) are brought into a value range of their reference data. The data structure itself is left unchanged and is as reported in Table 5-11.

5.4 Active Merging and Passive Merging

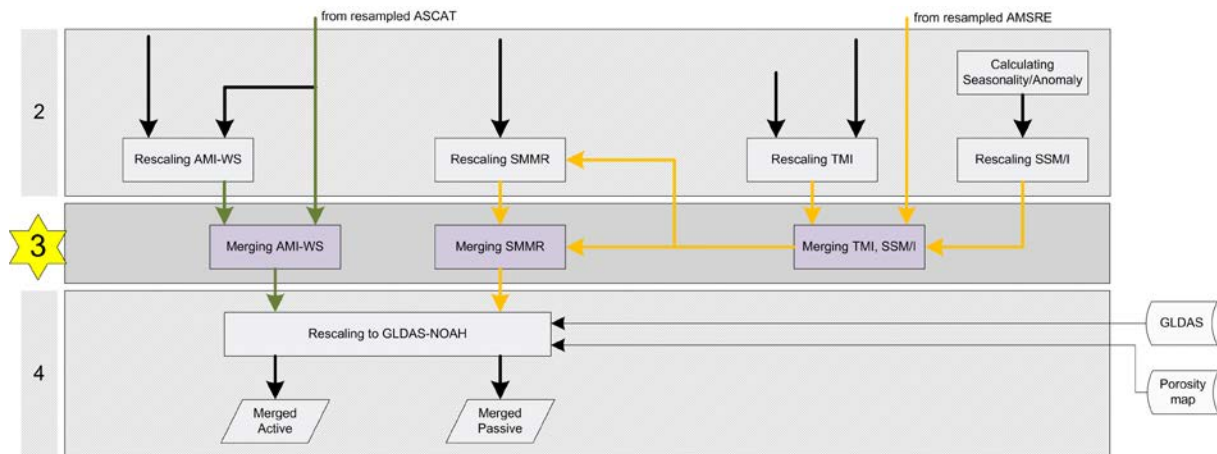

Figure 5-4 Processing step 3: Active Merging and Passive Merging

The merging of the AMI-WS and ASCAT needs the rescaled AMI-WS data coming from processing step 2 and the rescaled ASCAT data from processing step 1.

The merging of the passive data sets shows some more dependencies as Figure 5-5 depicts. First the rescaled SSM/I and the rescaled TMI are merged with AMSR-E. The output of this merging flows into the rescaling process as well into the merging of SMMR.

This processing step 3 creates as output data the merged active and the merged passive data. Data structures for both data sets are described in section 5.2.3 reported in Table 5-11.



5.5 Rescaling to GLDAS climatology

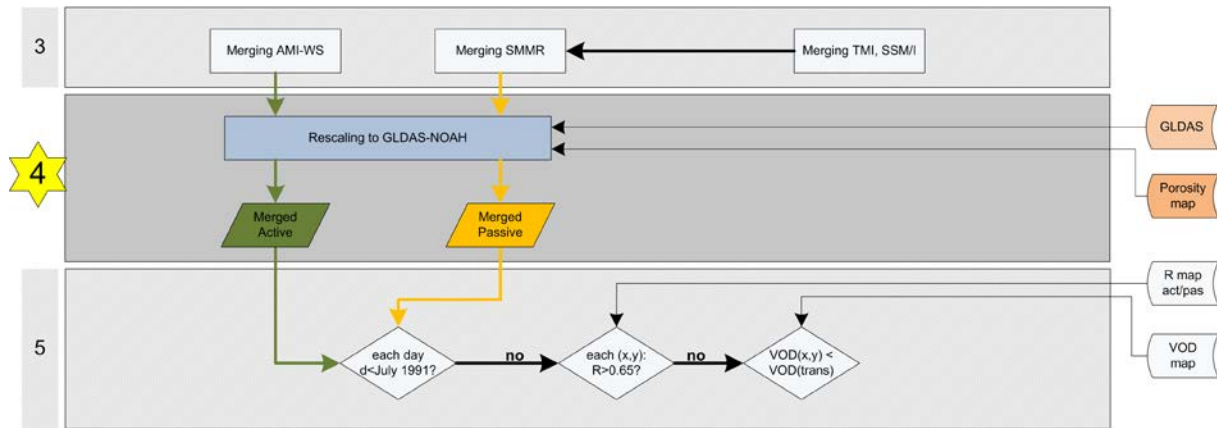

Figure 5-5: Processing step 4: Rescaling to GLDAS climatology

The merged active and the merged passive data sets need to be rescaled by CDF matching to the GLDAS-NOAH climatology. For this rescaling process two ancillary data sets are needed as input:

- a) the GLDAS NOAH is a reanalysis data set using the NOAH land surface model; layer 1 (0 – 10 cm)
- b) GLDAS Soil Porosity

This processing step creates the merged active and the merged passive data sets in the GLDAS climatology. The soil moisture and the soil moisture noise value are then brought into a range between 0 and 80. The data structure is described in section 5.2.3 reported in Table 5-11.



5.6 Combining Active and Passive Merged Data

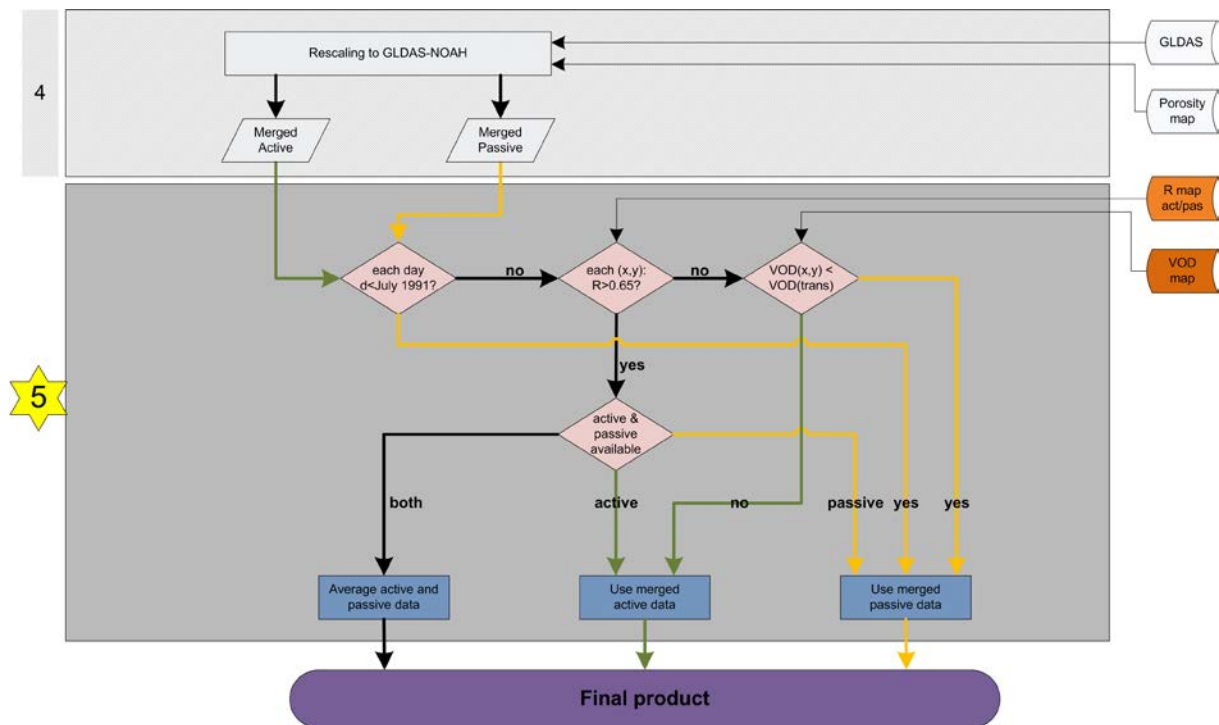

Figure 5-6 Processing step 5: Combining Active and Passive Merged data

The combination of the merged active and merged passive data, which have been brought into a common GLDAS climatology in the previous rescaling process, will need two additional ancillary data sets:

- the correlation coefficient map between ASCAT and AMSR-E (“R map act/pass”)
- the vegetation optical depth map, which is a global long-term passive microwave satellite-based retrievals of vegetation optical depth (“VOD map”)

During this processing step the final product will be created based on several decisions made by the use of input criteria from the ancillary data sets and by classifying the merged data sets into temporal coverage according to Figure 5-8. Depending on what data set and their combinations are used, the SENSOR variable (see section 5.2.3) is now completed by setting it accordingly from 7 to 10: SSM/I & AMI-WS (7), TRMM & AMI-WS (8), AMSR-E & AMI-WS (9), and AMSR-E & ASCAT (10). Also the variable FLAG will be set to either 0 (no flag), 1 (snow coverage or temperature below zero), 2 (dense vegetation), and 3 (others, e.g., no convergence in the model, thus no valid soil moisture estimates).

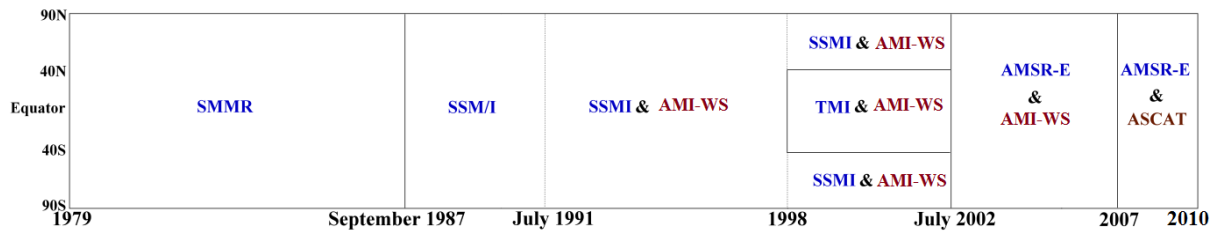

Figure 5-7 Spatial and temporal coverage of soil moisture products from different sensors in the final product.

The data structure output to the final product is as provided in Table 5-12

Variable	Type	Offset	Scale	Min physical value	Max physical value	Unit	Missing Value
JD	Double precision float	0	1	2443813.5 01-NOV-1991	2455561.5 31-DEC-2010	day	-999999.
SM	Float	0	1	–	–	–	-999999.
SM_NOISE	Float	0	1	0	–	–	-999999.
FLAG	Byte	0	1	0	255	–	255
SENSOR	Byte	0	1	1	10'	–	255

Table 5-12 Data Structure provided to the final product

6 Bibliography

Owe, M., de Jeu, R. and Holmes, T., 2008: Multisensor historical climatology of satellite-derived global land surface moisture. *Journal of Geophysical Research-Earth Surface* 113 (F1), F01002.

Wagner, W., Lemoine, G. and Rott, H., 1999: A Method for Estimating Soil Moisture from ERS Scatterometer and Soil Data. *Remote Sensing of Environment* 70, 191-207.